

Drawing NO.	AFS-AISG8Series	Ver. 1	Rev. 1
Part NO.	AISG8 Series		
Product Description	AISG RET Cable (AISG F-DB15)		Date: 2019.04.23
Draft: qianbo AFY/E	Checked: wangying AFY/Q	Approved: xuyiming AFY/MR	

Part NO.	Length (m)	Part NO.	Length (m)	Part NO.	Length (m)
AF9447	0.5	AF9453	50		
AF9448	3	AF9454	70		
AF9449	5				
AF9450	10				
AF9451	20				
AF9452	30				

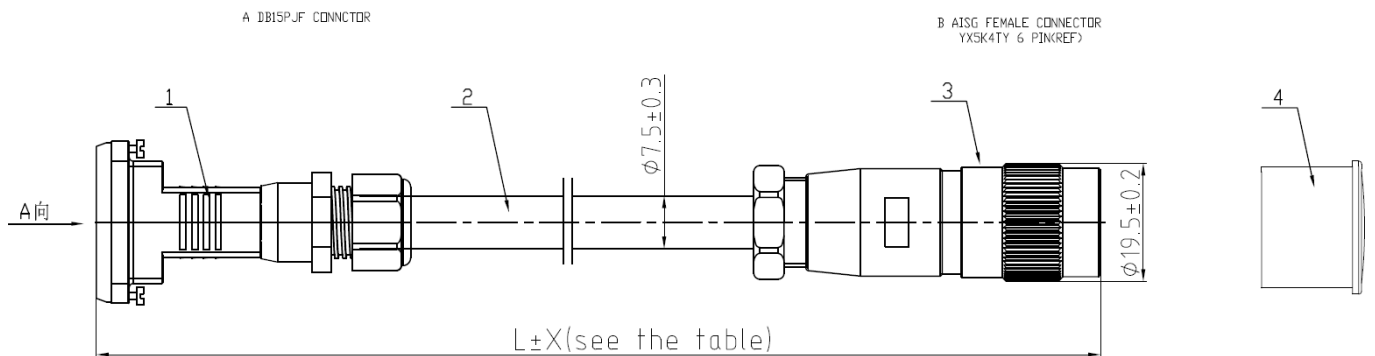

NOTE 1: TOLERANCE

$L > 3000\text{mm}$, $X=100$; $L \leq 3000\text{mm}$, $X=50$.

NOTE2: CONFIGURATION OF TERMINALS(PIN ASSY CHART)

DB15P JF	AISG-YX5K4T	WIRE COLOR	AWG	Pin Assignment
PIN9	PIN5	Blue	0.25mm ²	
PIN13	PIN3	Green	0.25mm ²	
PIN14	PIN7	Black	0.75mm ²	
PIN15	PIN6	Red	0.75mm ²	
The other pin is not connected				

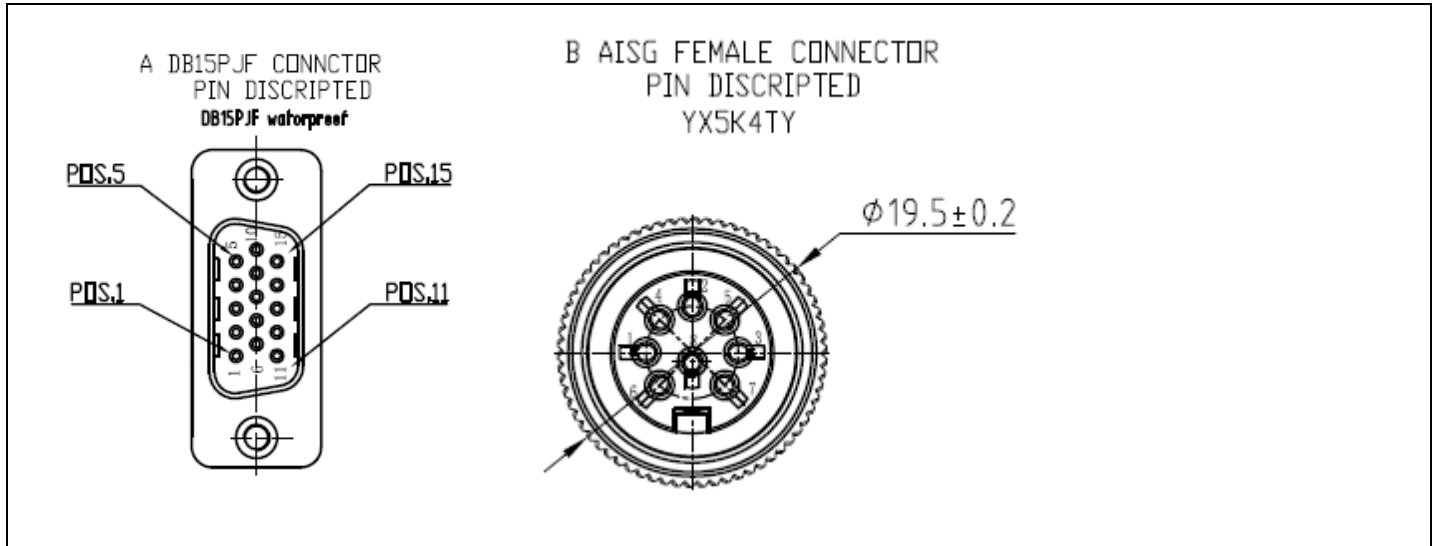

Reference Standard	IEC601309(AISG) IEC60807-2(DB15)
Electrical Performance	
Rated Voltage (V)	250V
Rated Impulse Withstand Voltage (V)	650V
Test Voltage (V)	670V
Insulation Resistance (Ω)	1000 M Ω (MIN)
Current Rating (A)	4A/40 $^{\circ}$ C
Contact Resistance (Ω)	10m ohm (MAX)
Characteristic Impedance(Ω)	100 \pm 20

Mechanical Performance	
Coupling style	Threaded
Mechanical Operating	500 mating cycles

Material and Plating		
Connector Parts	Material	Plating
Body	Brass	Nickel
Contact	Phosphor Bronze	Gold
Insulator	PBT 30%GLASS	
Over-mold	PVC	Black
Cable	UL2464 3C*0.75mm ² AWG+1p*0.25mm ²	
Protocol	AISG2.0	

Environment

Waterproofing Standard	IP67
Temperature Range	-40°C~+85°C
Storage Temperature	-45°C~+85°C
Relative Humidity	≤80%
Warranty	12 months
RoHS & WEEE	Compliant

Package

Package P/N: 521232

Package Size: 385*335*275

Part NO.	Length (m)	Quantity (pcs/ Carton)
9447	0.5	100
9448	3	30
9449	5	20
9450	10	15

Remark: Every AISG Cable must be individually packed with a plastic bag.

Notes

The technical specification contains proprietary information and such information may not be disclosed to others for any particular purpose or used for manufacturing purposes without written permission from Amphenol Fuyang.